

REPLACING A LESTEK 4412 14-VOLT REGULATOR WITH A PENNTEX PX-4000 14-VOLT REGULATOR IN A LESTEK CHARGING SYSTEM

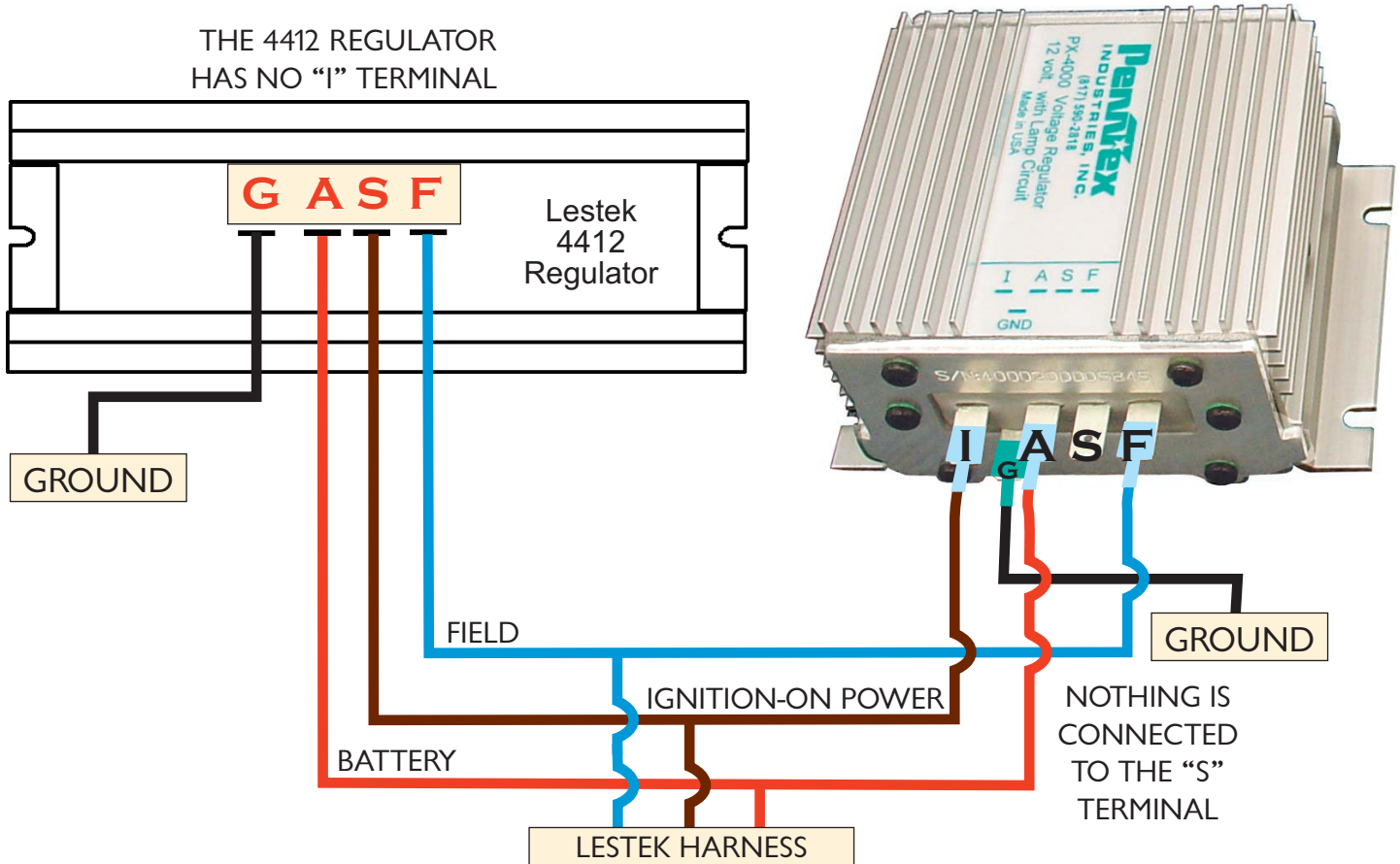

This diagram illustrates replacing a Lestek 4412 Voltage Regulator with a PennTex PX-4000 Voltage Regulator using a Lestek harness and Lestek alternator. Lestek charging system harness connections were not the same as PennTex harness connections and a standard PennTex Wiring Schematic doesn't apply.

PERFORMANCE, ENDURANCE AND SATISFACTION

PennTex
 INDUSTRIES, INC.

Manufacturers of
 High Efficiency Alternators and
 Mobile Electronic Devices.

Corporate:
 202 Plaza Drive
 Manchester, PA 17345
 Ph: 717/266-8762
 Fax: 717/266-7803

www.penntexusa.com
 Email: sales@penntexusa.com

Manufacturing:
 7620 Flagstone Drive
 Fort Worth, TX 76118
 Ph: 817/590-2818
 Toll Free: 877/590-7366
 Fax: 817/590-0505

