

**PI-1011
PENNTEX IDLE CONTROLLER
FOR
1996-UP 6.5 T.D. G-VAN D-B-W**

INSTALLATION:

******* DISCONNECT THE GROUND CABLE FROM ALL BATTERIES *******

1. Mount the idle controller (inside the vehicle) in a location that is both easily accessible to driver and within harnesses reach.
2. Connect the red wire from the idler to a source that provides +12 volts when the ignition switch is in the run position.
3. Connect the green wire from the idler to a white wire from the TCC/ Stop Lamp Switch. This wire should pull to +12 volts when the brake pedal is pressed.
4. Connect the yellow wire from the idler to a light green wire from the TCC/ Stop Lamp Switch. This wire should pull to +12 volts when the ignition switch is in the "RUN" position and the gear selector (automatic trans.) is in "PARK".
5. Connect the black wire from idler to chassis ground.
6. Remove glove box.
7. Disconnect the center connection from the PCM.
8. Remove the lock on the top of the connector that corresponds to row B.
9. Insert the terminal on the purple wire from the idler into cavity B7 9this is the seventh hole from the right in the back (wire side) of the connector shown below). Ensure that the terminal locks into the connector.
10. Reinstall the connector in the PCM.
11. Reinstall the glove box.
12. Secure all loose wires and harnesses away from heat sources, sharp edges or moving parts.

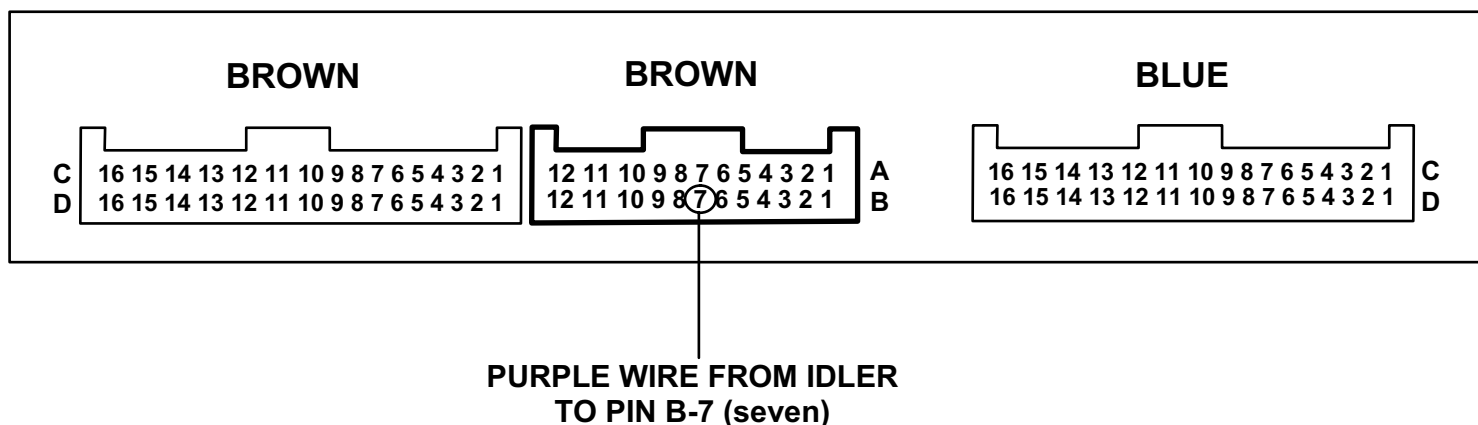

TESTING:

1. Reconnect all battery ground cables
2. Turn ignition switch to the "RUN" position but do not start engine. The "LOW" battery indicator (red) should be lit. After 10 seconds the "HIGH IDLE" indicator (yellow) should light up.
3. Press the brake pedal. The "HIGH IDLE" indicator should turn off. Release the brake and it should come back on with no delay.
4. Put the emergency brake on, press the brake pedal and move the gear selector to "DRIVE". Release the brake pedal. The "HIGH IDLE" indicator should not be lit. Put the shifter back in "PARK".\
5. Start the engine and press the "MANUAL ENGAGE" button. The "HIGH IDLE" indicator should light and the engine RPM should increase to 1360 rpm. Turn on all electrical loads. After the alternator has charged the battery up to 12.75 volts the "LOW" indicator should turn off and the "OK" indicator should turn on. Alternator may take a few minutes to recharge batteries before voltage can rise. Alternator must also be capable of putting out more current than the vehicle draws at a given RPM.
6. Press brake to insure that idle speed returns to normal.
7. Installation complete.