



PennTex INDUSTRIES, INC.

MODEL
PX-3 Series 28-Volt 175 amps

HIGH AMPERAGE / HEAVY DUTY ALTERNATORS / CHARGING SYSTEMS

PART NUMBERS:

COMPLETE KIT: PX-317S (INCLUDES PX-3S-175 ALTERNATOR, PA-4024
2.25" K8 PULLEY, PX-4024 REGULATOR & PX-3502-3 WIRE HARNESS)

ALTERNATOR ONLY: PX-3S-175



PX-3S-175

175/155 amps

PX-317 SERIES - TESTED AND PROVEN		
ROTOR RPM	AMPS @ 27.5 VOLTS	
	COLD (SAE)	HOT (200°F)
1800	50	40
2000	90	75
2250	110	90
2500	125	105
2750	130	110
3000	145	125
3500	155	135
4000	165	145
4500	170	150
5000	175	155

PROVEN DURABILITY



PX-4024 28 volt
Regulator

APPLICATIONS

- Buses, Ambulances, Command vehicles and Industrial applications that require high amperage output at engine idle.
- Contact PennTex for specific engine mounting application information.

OPTIONS

- Other voltages available.
- Contact PennTex for more information.

Special Features

- 1) 3/8" battery post.
- 2) Heavy duty hand wound high output stator.
- 3) Heavy duty long life brushes.
- 4) Heavy duty dual plane balanced rotor.
- 5) Heavy duty bearings with high temperature seals and grease.
- 6) Eighteen (18) press fit 60 amp diodes.
- 7) Specially designed heavy duty regulator which produces higher output ratings; runs cooler than current industry standards.
- 8) Regulator has ground fault and high voltage protection.
- 9) GXL wire is standard in all harnesses.
- 10) Standard OEM belt can be used in most applications.
- 11) Standard OEM mounting - no brackets needed in most applications.
- 12) Weight: approximately 25 pounds.

PennTex Industries recommends using a minimum of 2 gauge battery and ground cable. For maximum performance, route 2 gauge battery cable, or larger, from the alternator battery post directly to the battery positive stud. The ground wire from the alternator should be a minimum of 2 gauge cable and be bolted directly to a chassis ground or to the negative side of the battery.

WARRANTY

PENNTEx INDUSTRIES, INC., STANDARD WARRANTY IS EIGHTEEN (18) MONTHS OR 75,000 MILES -- WHICHEVER OCCURS FIRST, WHEN INSTALLED ON A NEW OEM VEHICLE. AFTERMARKET INSTALLATIONS HAVE A WARRANTY OF TWELVE (12) MONTHS/UNLIMITED MILES.

Dimensions

PX-3S-175

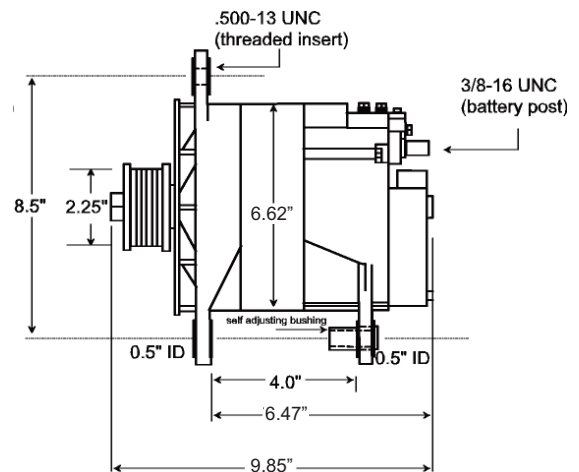

PERFORMANCE ENDURANCE AND SATISFACTION

Penntex
INDUSTRIES, INC.

Manufacturers of
High Efficiency Alternators and
Mobile Electronic Devices.

Corporate:
202 Plaza Drive
Manchester, PA 17345
Ph: 717/266-8762
Fax: 717/266-7803

www.penntexusa.com
E Mail: sales@penntexusa.com

Manufacturing:
7620 Flagstone Drive
Fort Worth, TX 76118
Ph: 817/590-2818
Toll Free: 877/590-7366
Fax: 817/590-0505

