

HIGH AMPERAGE / HEAVY DUTY ALTERNATORS / CHARGING SYSTEMS

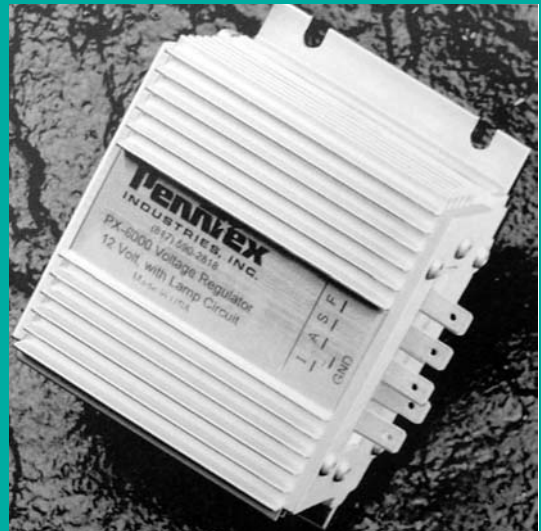

PX-6000 VOLTAGE REGULATOR

220 AMPS

MODEL PX-422V TESTED AND PROVEN		
ROTOR RPM	AMPS@ 13.5 VOLTS	
	80°F	200°F
1800	78	64
2000	109	90
2500	156	129
3000	179	149
3500	195	165
4000	204	174
4500	210	179
5000	216	184
6000	227	188

APPLICATIONS

- Specifically designed to mount bolt-for-bolt on the 2005-up C-3500, GMT-560 (C-4500/C-5500) and GMT-610 Chassis utilizing the 6.6L Duramax diesel and 8.1 gas engines.
- Buses and all other vehicles that require high amperage output.
- Contact PennTex for more information.

WARRANTY

PENNTEx INDUSTRIES, INC. STANDARD PX-422V WARRANTY IS EIGHTEEN (18) MONTHS OR 75,000 MILES – WHICHEVER OCCURS FIRST, WHEN INSTALLED ON A NEW OEM VEHICLE. AFTERMARKET INSTALLATIONS HAVE A WARRANTY OF TWELVE (12) MONTHS/UNLIMITED MILES.

Special Features

- 1) 5/16" positive output post.
- 2) 90-110 amps output at engine idle.
- 3) Heavy duty hand wound high output stator.
- 4) High temperature bearings.
- 5) Twelve (12) press fit 60 amp diodes..
- 6) Newly designed high temperature rectifier.
- 7) Specially designed heavy duty regulator that produces higher output ratings; runs cooler than current industry standards.
- 8) Eighteen (18) press fit 60 amp diodes.
- 9) GXL wire is standard in all harnesses.
- 10) Utilizes OEM mounting configurations and OEM belt - no brackets or belt change needed.
- 11) Weight: approximately 17 pounds.

PennTex Industries recommends using a minimum of 2 gauge battery and ground wire. For maximum performance, route 2 gauge battery cable, or larger from the alternator battery post directly to the battery positive stud. The ground wire from the alternator should also be a minimum of 2 gauge cable and should be bolted directly to a chassis ground or the the negative side of the battery.

Dimensions

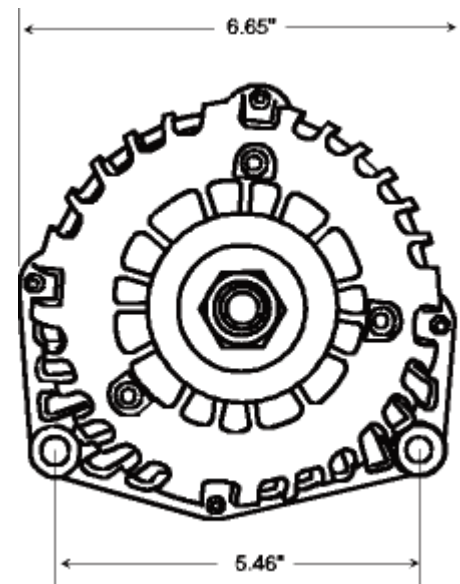
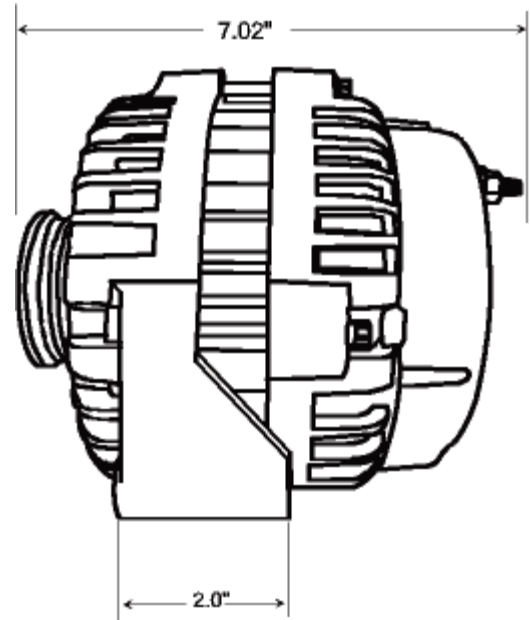

PERFORMANCE, ENDURANCE AND SATISFACTION

PennTex
INDUSTRIES, INC.

Manufacturers of
High Efficiency Alternators and
Mobile Electronic Devices.

Corporate:
202 Plaza Drive
Manchester, PA 17345
Ph: 717/266-8762
Fax: 717/266-7803

www.penntexusa.com
E Mail: sales@penntexusa.com

Manufacturing:
7620 Flagstone Drive
Fort Worth, TX 76118
Ph: 817/590-2818
Toll Free: 877/590-7366
Fax: 817/590-0505

