

INSTALLING A PX-3S ALTERNATOR ON A VEHICLE THAT HAD A LESTEK B270 or B300 AND "TWO YELLOW WIRES" 14-VOLT VOLTAGE REGULATOR & HARNESS

**DON'T CONNECT ANYTHING HERE ON THE PENNTEX ALTERNATOR**

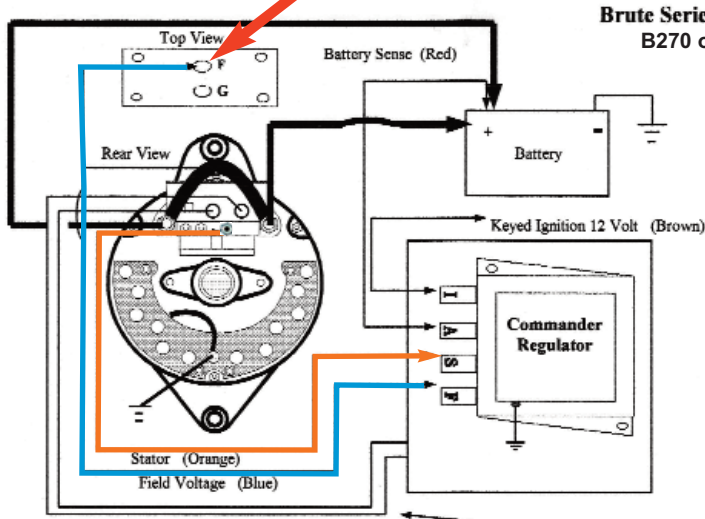

YELLOW WIRES ARE A "SUPERCHARGER" FEATURE PENNTEX DOESN'T USE.

PX-#S-285 OR PX-3S-305 ALTERNATOR CONNECTIONS

PennTex Replacements:  
 PX-3S-285 Alternator  
 PX-4000 Regulator  
 PX-3502-3 Harness  
 or: PX-328S Complete Kit

**OR:**  
 PX-3S-305 Alternator  
 PX-4000 Regulator  
 PX-3502-3 Harness  
 or: PX-330S Complete Kit

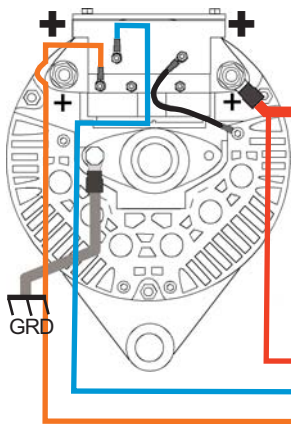

NOTE: THERE ARE MAJOR DIFFERENCES BETWEEN LESTEK CONNECTION POINTS AND PENNTEX CONNECTION POINTS. ALWAYS FOLLOW PENNTEX INSTRUCTIONS WHEN INSTALLING A PENNTEX SYSTEM.

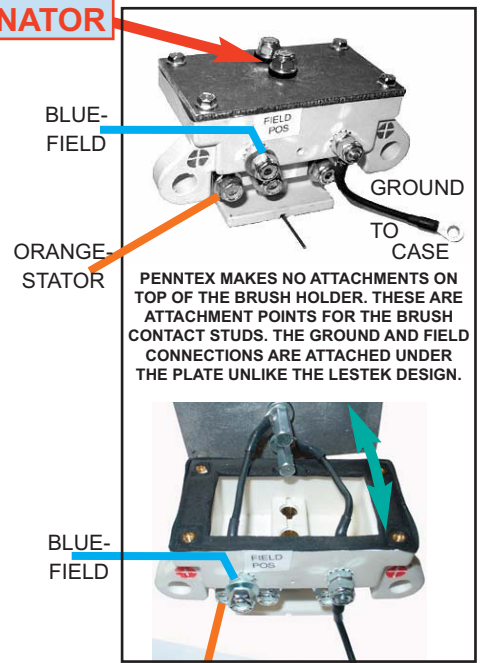

PENNTEX MAKES NO ATTACHMENTS ON TOP OF THE BRUSH HOLDER. THESE ARE ATTACHMENT POINTS FOR THE BRUSH CONTACT STUDS. THE GROUND AND FIELD CONNECTIONS ARE ATTACHED UNDER THE PLATE UNLIKE THE LESTEK DESIGN.

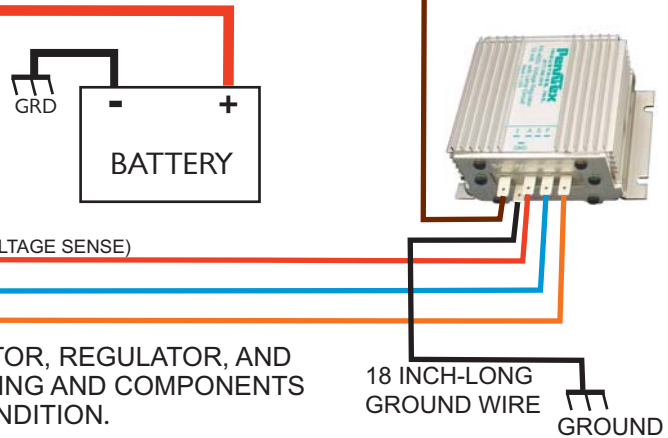

IT'S RECOMMENDED THAT THE COMPLETE ALTERNATOR, REGULATOR, AND HARNESS BE REPLACED RATHER THAN REUSING WIRING AND COMPONENTS THAT COULD BE IN QUESTIONABLE CONDITION.

**PERFORMANCE, ENDURANCE AND SATISFACTION**

**PenTex**  
 INDUSTRIES, INC.

Manufacturers of  
 High Efficiency Alternators and  
 Mobile Electronic Devices.

**Corporate:**  
 202 Plaza Drive  
 Manchester, PA 17345  
 Ph: 717/266-8762  
 Fax: 717/266-7803

[www.pentexusa.com](http://www.pentexusa.com)  
 Email: [sales@pentexusa.com](mailto:sales@pentexusa.com)

**Manufacturing:**  
 7620 Flagstone Drive  
 Fort Worth, TX 76118  
 Ph: 817/590-2818  
 Toll Free: 877/590-7366  
 Fax: 817/590-0505

